



Configuring a KlasTA to HotDial with a KIV-7 using AERO

KB article reference no. Q103109

Version: 1.0

Keywords: KlasTA, KIV-7, HotDial, AERO

The information in this article applies to:

- o KlasTA
- o KIV-7

Table of Contents

1.0 Introduction.....	2
2.0 Cable Connections	2
3.0 Configure the KIV-7 to work with KlasTA	3
4.0 Configuring KlasTA	3

Table of Figures

Figure 1. Sample Scenario using the KIV-7 for Type-1 Encryption	2
Figure 2. KlasTA Configuration Main Screen.....	3
Figure 3. KlasTA Configuration Profiles Screen.....	4
Figure 4. KlasTA Input Device Screen.....	4
Figure 5. KlasTA Network Type Screen	5
Figure 6. KlasTA Bonding Mode Screen	5
Figure 7. KlasTA Dial and Answer Screen	6
Figure 8. KlasTA Dial Parameters Screen.....	6
Figure 9. KlasTA H.320 VTC Screen.....	7
Figure 10. KlasTA Extra Configuration Commands Screen	7
Figure 11. KlasTA Configuration Summary Screen.....	8
Figure 12. KlasTA Configuration Progress Screen	8
Figure 13. KlasTA Profile Screen.....	9

1.0 Introduction

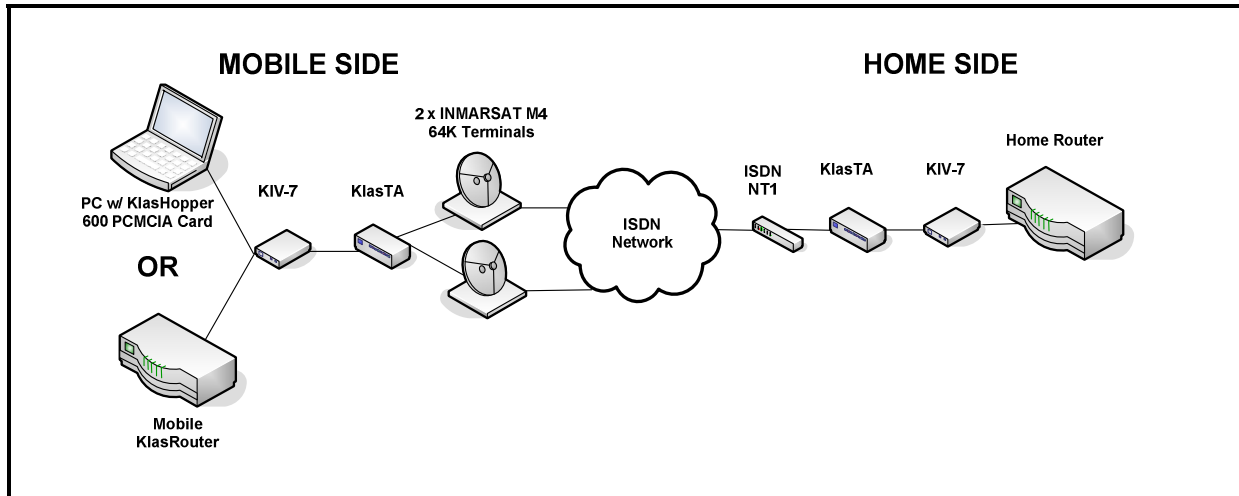

Figure 1. Sample Scenario using the KIV-7 for Type-1 Encryption

This document describes how to configure a KlasTA connected to a KIV-7 in order to HotDial a 128K connection using two 64K INMARSAT satellite terminals. The HotDial option uses the DTR signal from the Red-Side communication device (i.e. KlasHopper or KlasRouter) to prompt KlasTA to initiate the dialing sequence. Conversely, once DTR is lowered, KlasTA will close the connection after a specified time period.

In this example, KlasTA uses the AERO protocol in order to multiplex the data stream from the RS-530 synchronous serial port into two individual 64K channels. These channels will be sent through the two ISDN Output ports on the KlasTA connected to the INMARSAT terminals. Follow the directions in the sections below outlining the steps from the KlasTA configuration wizard.

2.0 Cable Connections

Prior to beginning, ensure the following cable connections have been properly secured:

1. Power cord is plugged in and KlasTA is on.
2. Control Port Cable is connected to the PC's serial port.
3. Control Port Cable is connected to the 'Control' port on the front of the KlasTA.
4. Black KIV-7 cable is connected to the male RS-530 connector of the KIV-7 and the female RS-530 synchronous serial port on the KlasTA.
5. ISDN cables are connected to the RJ-45 ISDN Output Ports 1 and 2 from KlasTA and the ISDN ports on each M4 Terminal.

Configure a KlasTA to HotDial with a KIV-7 using AERO

3.0 Configure the KIV-7

The KIV-7 has a specific sequence of settings that allow it to encrypt data using the RS-530 serial data port. Follow the instructions from Application Note Q100004 in order to configure the KIV-7 so that it will work properly with KlasTA.

4.0 Configuring KlasTA

Open the KlasTA configuration application on your PC. Follow the steps below to configure KlasTA.

1. Click on the 'Configure' button on the opening menu.

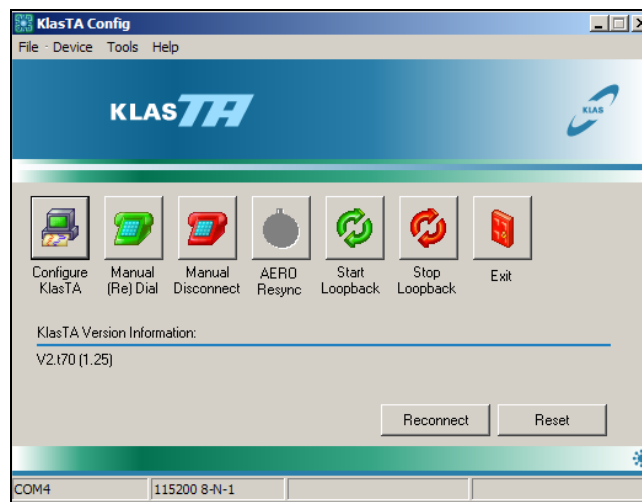

Figure 2. KlasTA Configuration Main Screen

2. Check the 'Configure KlasTA using step-by-step wizard' radio button. Click the 'Next' button to continue and move on to the next configuration screen.

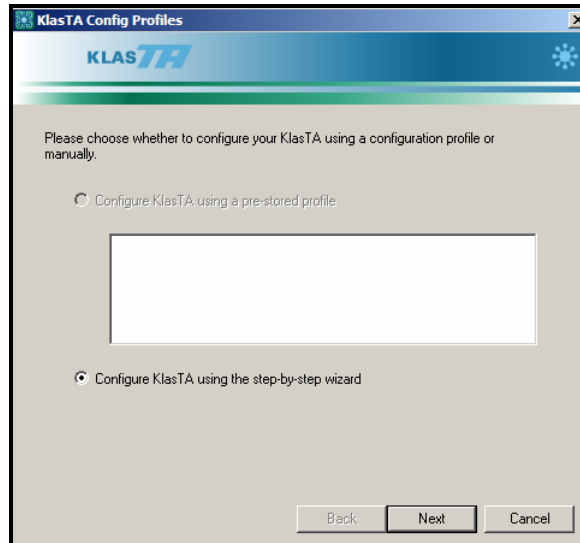

Figure 3. KlasTA Configuration Profiles Screen

3. Check the Encryption Device radio button and select KIV-7 as the Encryption Device from the pull-down menu. **(Note: This parameter must be identical for the KlasTAs on both sides of the call.)**

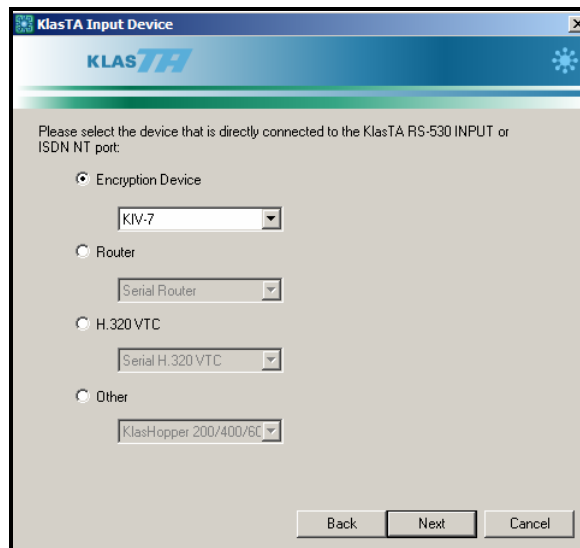

Figure 4. KlasTA Input Device Screen

Configure a KlasTA to HotDial with a KIV-7 using AERO

4. Select the 'Satellite' radio button indicating you will be dialing from a satellite terminal.

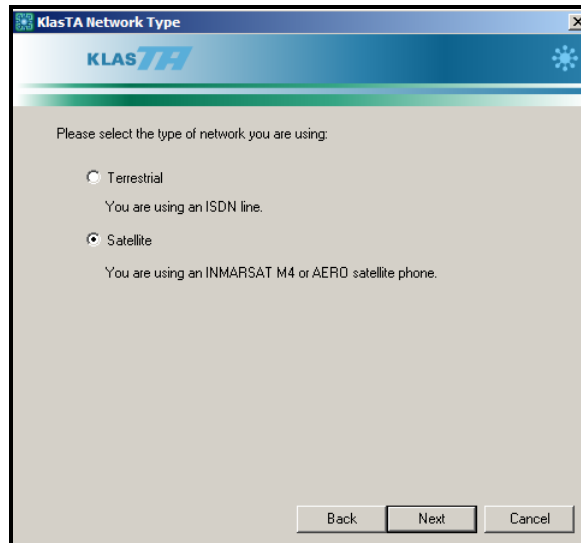

Figure 5. KlasTA Network Type Screen

5. Select the 'KLAS AERO' radio button indicating that both KlasTAs will be using the AERO protocol.

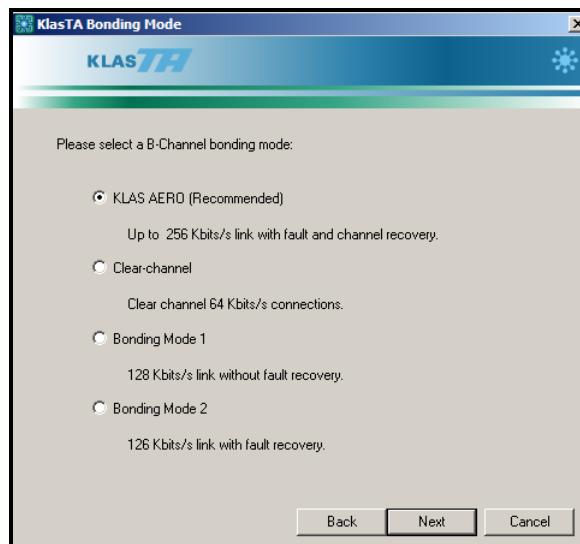

Figure 6. KlasTA Bonding Mode Screen

Configure a KlasTA to HotDial with a KIV-7 using AERO

- Select the 'Dial and Answer' radio button to enable KlasTA to initiate the dialing sequence. Also, check the 'Dial when DTR goes high (Hotdial)' radio button. This option specifies that KlasTA will only dial when DTR is asserted. If you are using a DTR switch cable, check the 'I am using a DTR switch cable...' box. Finally, you can specify the DTR drop disconnect timeout. The default is 30 seconds and this value represents the amount of time KlasTA will wait once DTR is lowered before it automatically closes the connection.

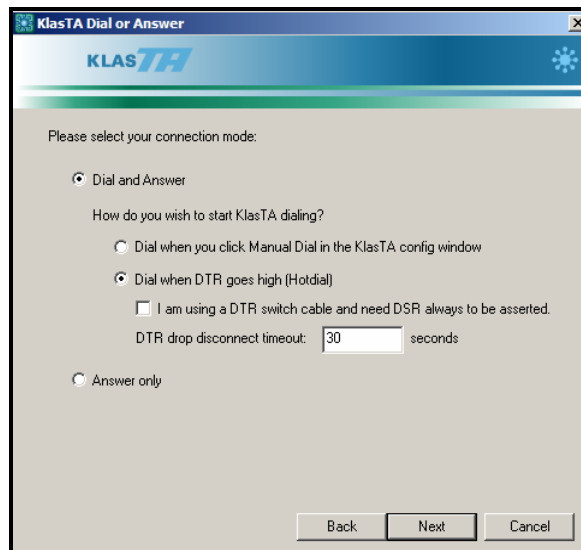

Figure 7. KlasTA Dial and Answer Screen

- Input the dial strings of the opposite KlasTA you would like to call. Since this is a 128K call, there are two 64K B-channels. Check the B2 box and then enter the two dial strings associate with each 64K channel. Ensure you type in '#' after the last digit in the dial string indicating to the KlasTA that the last number has been dialed.

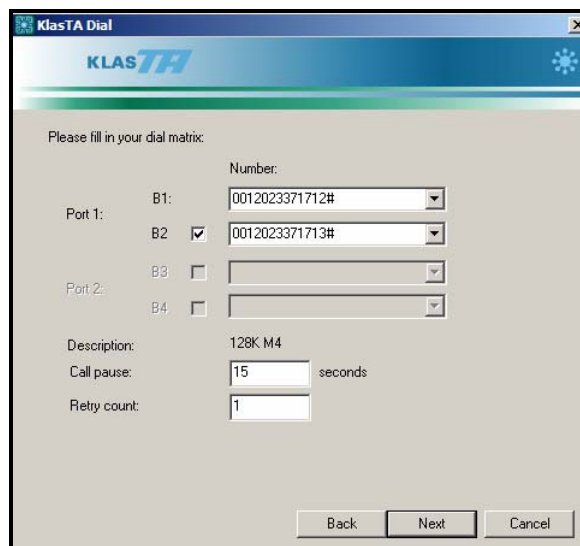

Figure 8. KlasTA Dial Parameters Screen

Configure a KlasTA to HotDial with a KIV-7 using AERO

8. The KlasTA Aero 56K menu screen is designed for compatibility with H.320 Video Conferencing. The H.320 VTC protocol is based on the ISDN format and only operates at intervals of 64K and 56K. Since the Aero protocol uses one out of 64 bytes for bandwidth management, the actual throughput is 63K which will not work at the 64K H.320 variant. Therefore, when using the Aero protocol, you must use the 56K version of the H.320 VTC protocol. If you plan to conduct an H.320 VTC, check the box; otherwise, leave the box unchecked.

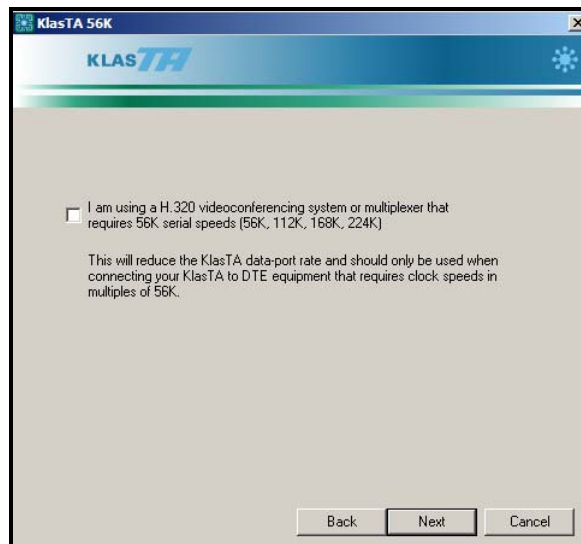

Figure 9. KlasTA H.320 VTC Screen

9. The Extra Config Commands screen allows you to enter manual commands that enable seldom used features. No extra configuration commands are needed for this setup.

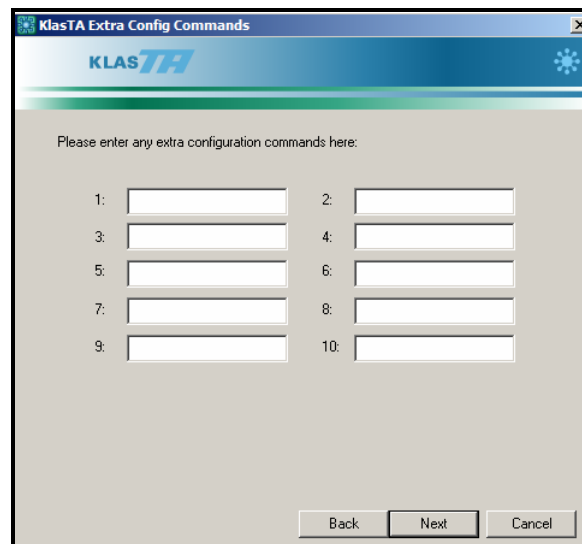

Figure 10. KlasTA Extra Configuration Commands Screen

Configure a KlasTA to HotDial with a KIV-7 using AERO

10. Review the configuration options to ensure they are correct and then click on the 'Configure' button to initiate the configuration sequence on the KlasTA.

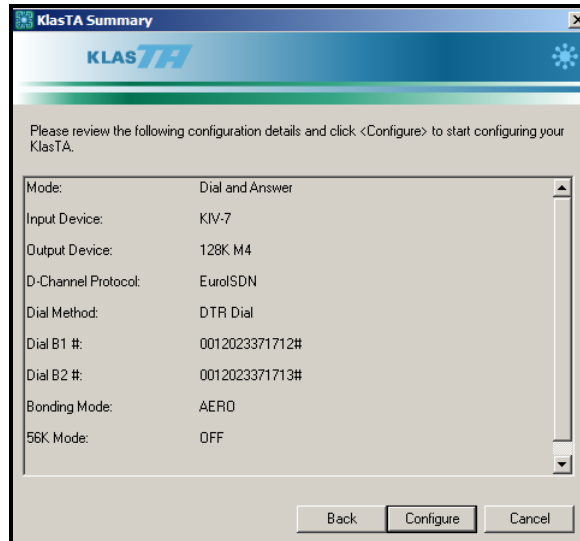

Figure 11. KlasTA Configuration Summary Screen

11. Click on the 'OK' button once the configuration sequence has successfully completed.

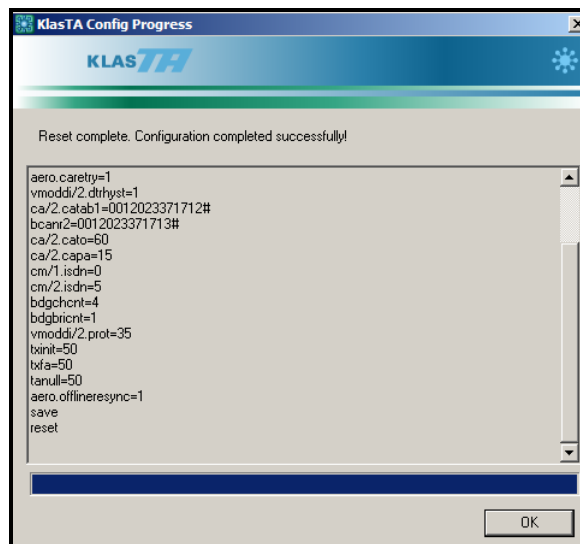

Figure 12. KlasTA Configuration Progress Screen

Configure a KlasTA to HotDial with a KIV-7 using AERO

12. If desired, click the 'Yes' radio button to save this configuration. Click on the 'Finish' button to go back to the Main Menu.

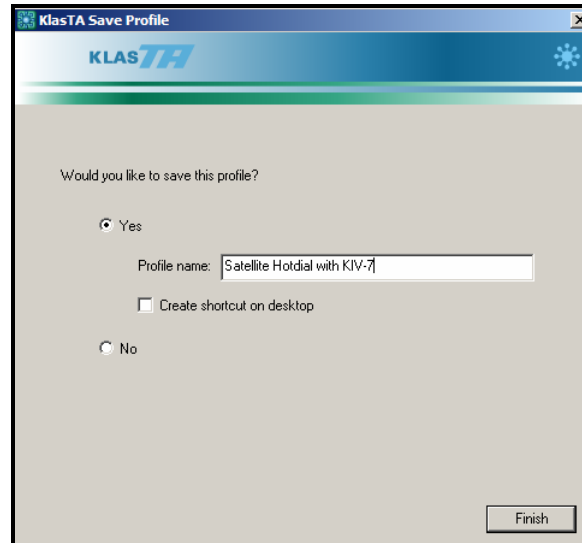

Figure 13. KlasTA Profile Screen

MORE INFORMATION

For more information about KlasTA and other Klas products, visit the following Klas website:

<www.klasonline.com>

Copyright © 2005 Klas Ltd. All rights reserved. All company and brand names are trademarks or registered trademarks of their respective owners.

DISCLAIMER OF WARRANTY: THE DOCUMENT IS PROVIDED AS IS, WITHOUT WARRANTY OF ANY KIND. TO THE MAXIMUM EXTENT PERMITTED BY APPLICABLE LAW, WITH RESPECT TO THE DOCUMENT AND / OR ANY ASSOCIATED ON-LINE INFORMATION, KLAS DISCLAIMS ALL WARRANTIES, EITHER EXPRESS OR IMPLIED, INCLUDED BUT NOT LIMITED TO IMPLIED WARRANTIES OF MERCHANTABILITY AND FITNESS FOR A PARTICULAR PURPOSE, AND NONINFRINGEMENT.

Configure a KlasTA to HotDial with a KIV-7 using AERO